

PD-801 Multi-Press

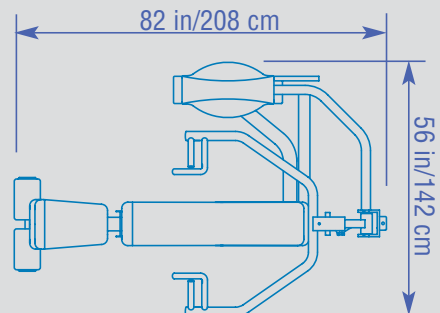

- Multi-purpose bench adjusts from decline to the full upright position
- Press bar arm easily adjusts for decline, flat incline and shoulder presses
- Multiple grip handles on the press arm allow for variation of exercises and muscle isolation
- Built-in padded footroll support
- 200 lbs. steel weight stack



Ht: 55 in/140 cm
Wt: 575 lb/261 kg